

(TL)

**Oil/Air-
Cooling Systems**

AKG-Range
TL1 - TL6



T e c h n i c a l Specification



Your innovative partner to design and supply engineered cooling packages



General

Our TL range is designed to help you find an individual solution for your cooling application. Our TL cooling systems offer a wide variety of products which have been fully tried and tested, even under arduous working conditions.

A range of six basic types covers almost all cooling applications, involving a large variety of fluids in stationary and mobile machines.

AKG and its representatives as experts in the field of cooling systems will be delighted to assist you.

As part of our ongoing technical improvements, AKG maintains the right to introduce modifications to the specifications in this brochure.

Features

- Cooling systems are made from Aluminium
- Fully tried and tested for arduous working conditions
- Ideal for mobile machines
- Maximum working pressure 14 bar
- Offering a high flexibility for usage in transmission, hydraulic, engine and lubrication oils
- Cooling systems can be fitted with 12/24V DC and 3 Phase motors

Benefits

- Short lead times
- Cost effective
- Cooling systems fully equipped for immediate use
- Easy to install
- Spares from stock
- Maintenance free

Applications

The units can be used for cooling: mineral oil, synthetic oil, bio oil, HFA B C D liquids, water/glycol mixture, containing 50 % antifreeze and corrosion inhibitors

Function: Heat will be transferred from the fluid to the cooling air flow

Oil/Air-Cooling Systems

AKG-Range
TL1 - TL6



(TL)

Please note:

- Set up and operating instructions
- General Terms of Sales and Delivery
- Spares list

Technical Data

TL1 - TL6, with DC fan motor...

including shroud

without shroud

3 Phase motor

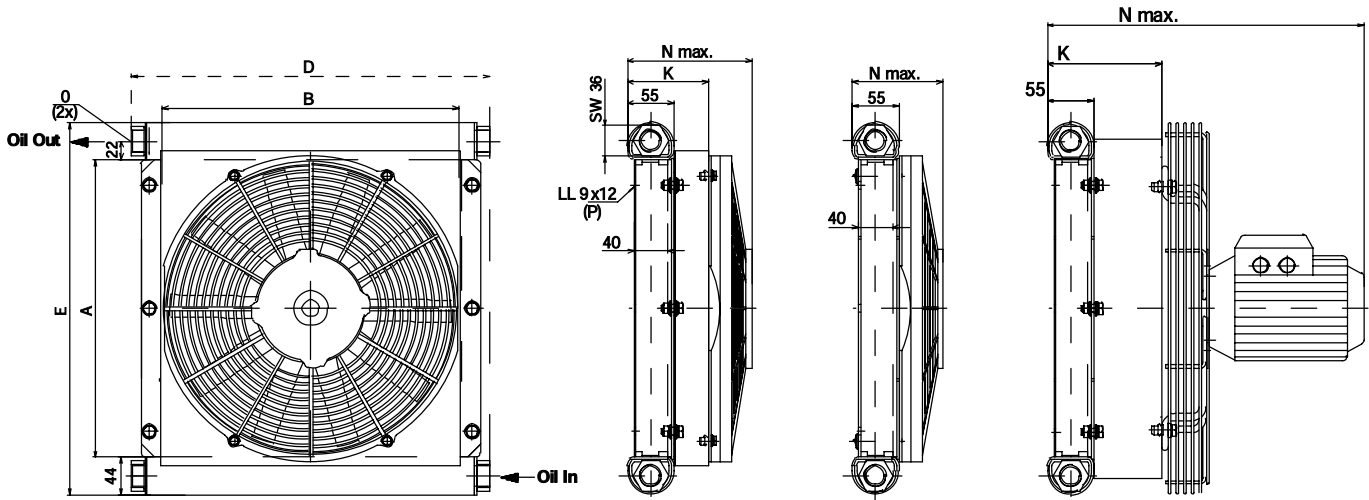

SPECIFICATION

Cooler Type		TL1	TL2	TL3	TL4	TL5	TL6
Heat rejection ¹⁾		1-4.5	2-7	3-13	5-16	6-20	10-35
TL1-TL6, with DC fan motor, including shroud		DIMENSIONS					
A	mm	150	200	250	300	350	600
B	mm	154	203	252	301	350	301
D	mm	227	276	325	372	422	374
E	mm	238	288	338	388	438	688
F	mm	1 x 90	1 x 140	1 x 190	1 x 240	2 x 145	2 x 270
H	mm	184	233	282	331	380	331
K	mm		95	95	95	95	95
N max.	mm	145.5	147	147	147	147	147
O		G 1/2	G 3/4	G 3/4	G 3/4	G 3/4	G 3/4
P	mm	4x	4x	4x	4x	6x	6x
A x B	m ²	0.0231	0.0406	0.0630	0.0902	0.1223	0.1804
Without shroud							
N max.	mm	-	107	107	107	107	107
3 Phase motor							
K	mm	-	135	112	112	135	255
N max.	mm		180	320	320	380	510

ORDER CODE SYSTEM

574 . 2 . 0000

Cooler type: e.g. 2 = TL2

Direction of cooling air flow: pulling

- 01 = 12 V DC including shroud
- 02 = 24 V DC including shroud
- 03 = 3 Phase motor including shroud
- 21 = 12 V DC without shroud
- 22 = 24 V DC without shroud

1) For details use diagrams and tables as appropriate
 2) All systems are pressure tested according to DIN 50104

Cooler Type	Order Number	Fan Diameter [mm]	Fan Speed [rpm]	Noise Level [dB(A), 1m]	Motor Voltage [V]	Current [Amp]	Power Consumption [kW]	Volume [l]	Working Pressure [bar]	Total Weight excluding fluid [kg]
TL1	5741.201.0000	140	4780	68	12	3.4	0.04	0.7	14	2.4
	5741.202.0000	140	4770	68	24	1.7	0.04	0.7	14	2.4
TL2	5742.201.0000	167	4250	76	12	6.5	0.08	1.0	14	4.4
	5742.202.0000	167	4350	76	24	3.6	0.09	1.0	14	4.4
	5742.221.0000	167	4250	77	12	6.5	0.08	1.0	14	3.6
	5742.222.0000	167	4350	77	24	3.6	0.09	1.0	14	3.6
	5742.203.0000	170	1500	63	230/400	0.12	0.04	1.0	14	5.6
TL3	5743.201.0000	225	3400	76	12	7.7	0.09	1.1	14	5.5
	5743.202.0000	225	3260	76	24	3.9	0.09	1.1	14	5.5
	5743.221.0000	225	3400	76	12	7.7	0.09	1.1	14	4.6
	5743.222.0000	225	3260	76	24	3.9	0.09	1.1	14	4.6
	5743.203.0000	250	3000	81	230/400	0.79	0.25	1.1	14	12.0
TL4	5744.201.0000	280	3280	80	12	9.2	0.12	1.7	14	7.4
	5744.202.0000	280	3260	80	24	4.7	0.12	1.7	14	7.4
	5744.221.0000	280	3280	79	12	9.2	0.12	1.7	14	6.2
	5744.222.0000	280	3260	79	24	4.7	0.12	1.7	14	6.2
	5744.203.0000	280	3000	82	230/400	0.79	0.25	1.7	14	14.0
TL5	5745.201.0000	330	2600	75	12	7.9	0.10	2.0	14	8.3
	5745.202.0000	330	2620	75	24	4.1	0.10	2.0	14	8.3
	5745.221.0000	330	2600	71	12	7.9	0.10	2.0	14	7.0
	5745.222.0000	330	2620	71	24	4.1	0.10	2.0	14	7.0
	5745.203.0000	350	1500	72	230/400	0.5	0.12	2.0	14	15.0
TL6	5746.201.0000	2 x 280	3280	85	12	2 x 9.2	2 x 0.12	2.4	14	14.0
	5746.202.0000	2 x 280	3260	85	24	2 x 4.7	2 x 0.12	2.4	14	14.0
	5746.221.0000	2 x 280	3280	81	12	2 x 9.2	2 x 0.12	2.4	14	13.0
	5746.222.0000	2 x 280	3260	81	24	2 x 4.7	2 x 0.12	2.4	14	13.0
	5746.203.0000	1 x 300	3000	81	230/400	1.0	0.37	2.4	14	20.0

3 Phase motor: B14 small flange
Depending on the motor the current and power will vary.
For details see the name plate.

Materials

Cooler:	Aluminium
Fan blade:	Plastic
Fan shroud, finger guard:	Steel (Zinc plated), Painted/Powder coated

Easy sizing of TL-coolers

The following tables may be used to quickly select a TL-cooler.

The data is based on the assumption that oil inlet temperature does not exceed 70 °C for hydraulic and 110 °C for lubrication applications.

Please use the following heat rejection figures if no details are available:

- Agricultural and construction machinery: 1/3 of Diesel engine power
- Hydraulic pumps driven by an electric motor: 1/3 of electric motor power

Hydraulic applications

Heat rejection [kW @ 30 °C ambient temperature]											
Oil flow in l/min	TL1	TL2	TL3	TL4	TL5	TL6	TL2	TL3	TL4	TL5	TL6
Including shroud						Without shroud, fitted with 12/24V DC fan motor					
10	1.8										
20	2.0	3.0	4.8	6.8	8.4	12.8	2.2	3.2	6.0	6.2	10.4
30	2.2	3.2	5.2	7.0	8.6	13.2	2.4	3.6	6.2	6.4	10.8
50		3.4	5.6	7.2	8.8	14.0	2.6	4.2	6.6	6.8	11.6
60		3.6	5.8	7.4	9.0	14.4	2.8	4.4	6.8	7.2	12.2
80			6.4	7.6	9.2	15.2		4.8	7.0	7.4	13.0
100				8.0	9.4	16.0			7.2	7.8	13.2
120					9.6	16.2				8.0	13.6
150						16.4					14.4

Heat rejection [kW @ 40 °C ambient temperature]											
Oil flow in l/min	TL1	TL2	TL3	TL4	TL5	TL6	TL2	TL3	TL4	TL5	TL6
Including shroud						Without shroud, fitted with 12/24V DC fan motor					
10	1.4										
20	1.5	2.3	3.6	5.1	6.3	9.6	1.7	2.4	4.5	4.7	7.8
30	1.7	2.4	3.9	5.3	6.5	9.9	1.8	2.7	4.7	4.8	8.1
50		2.6	4.2	5.4	6.6	10.5	2.0	3.2	5.0	5.1	8.7
60		2.7	4.4	5.6	6.8	10.8	2.1	3.3	5.1	5.4	9.2
80			4.8	5.7	6.9	11.4		3.6	5.3	5.6	9.8
100				6.0	7.1	12.0			5.4	5.9	9.9
120					7.2	12.2				6.0	10.2
150						12.3					10.8

Easy sizing of TL-coolers

For a more detailed and customised cooler selection exact temperatures and flows are necessary. Please select your cooler according to the example on page 10 or seek advice from AKG or its representatives.

Lubrication oil applications

Heat rejection [kW @ 30 °C ambient temperature]											
Oil flow in l/min	TL1	TL2	TL3	TL4	TL5	TL6	TL2	TL3	TL4	TL5	TL6
Including shroud						Without shroud, fitted with 12/24V DC fan motor					
10	3.6										
20	4.0	6.0	9.6	13.6	16.8	25.6	4.4	6.4	12.0	12.4	20.8
30	4.4	6.4	10.4	14.0	17.2	26.4	4.8	7.2	12.4	12.8	21.6
50		6.8	11.2	14.4	17.6	28.0	5.2	8.4	13.2	13.6	23.2
60		7.2	11.6	14.8	18.0	28.8	5.6	8.8	13.6	14.4	24.4
80			12.8	15.2	18.4	30.4		9.6	14.0	14.8	26.0
100				16.0	18.8	32.0			14.4	15.6	26.4
120					19.2	32.4				16.0	27.2
150						32.8					28.8

Heat rejection [kW @ 40 °C ambient temperature]											
Oil flow in l/min	TL1	TL2	TL3	TL4	TL5	TL6	TL2	TL3	TL4	TL5	TL6
Including shroud						Without shroud, fitted with 12/24V DC fan motor					
10	3.2										
20	3.5	5.3	8.4	11.9	14.7	22.4	3.9	5.6	10.5	10.9	18.2
30	3.9	5.6	9.1	12.3	15.1	23.1	4.2	6.3	10.9	11.2	18.9
50		6.0	9.8	12.6	15.4	24.5	4.6	7.4	11.6	11.9	20.3
60		6.3	10.2	13.0	15.8	25.2	4.9	7.7	11.9	12.6	21.4
80			11.2	13.3	16.1	26.6		8.4	12.3	13.0	22.8
100				14.0	16.5	28.0			12.6	13.7	23.1
120					16.8	28.4				14.0	23.8
150						28.7					25.2

Specific heat rejection TL1 - TL6

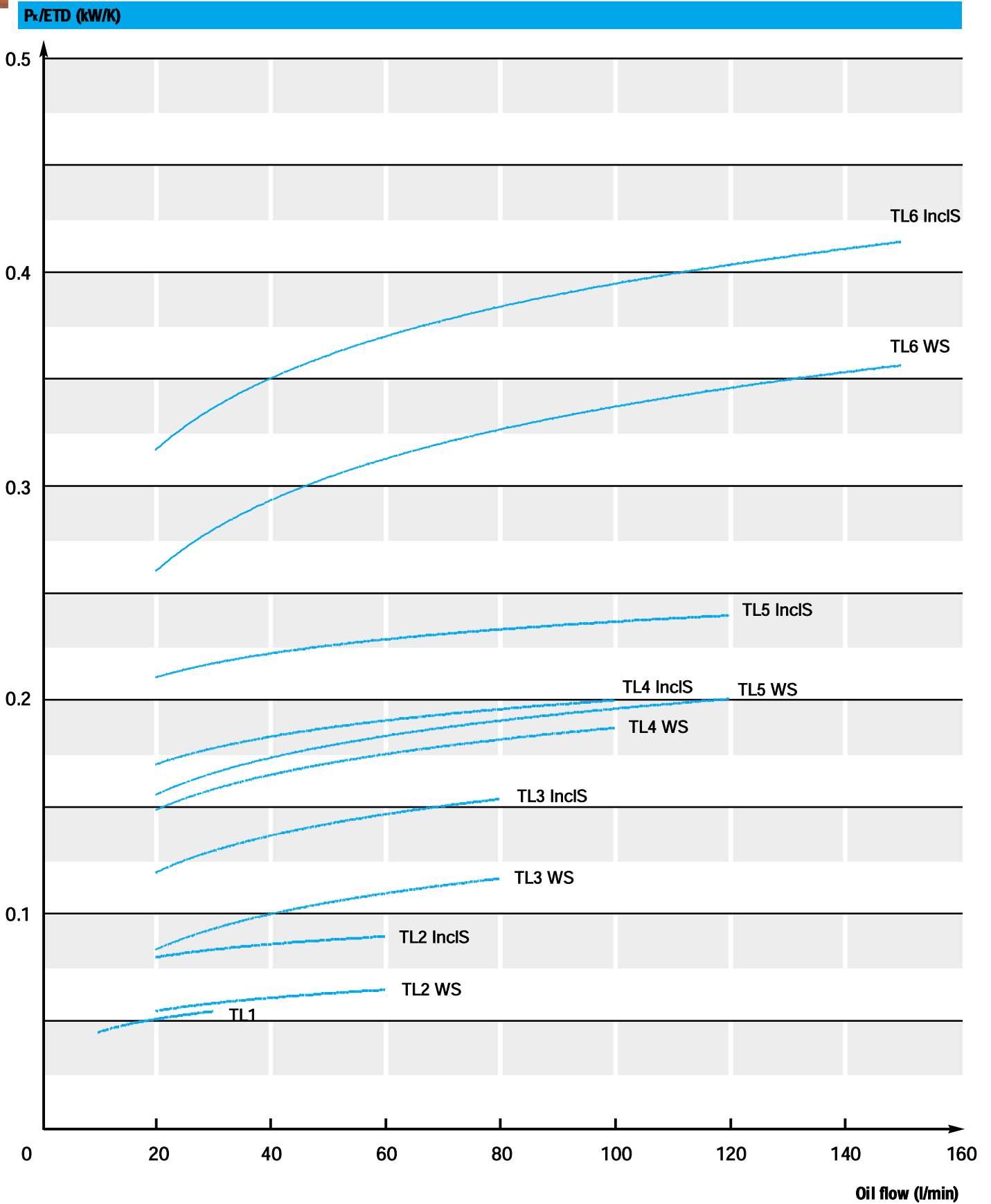

InclS = Including shroud

WS = Without shroud

Pressure drop TL1 - TL6

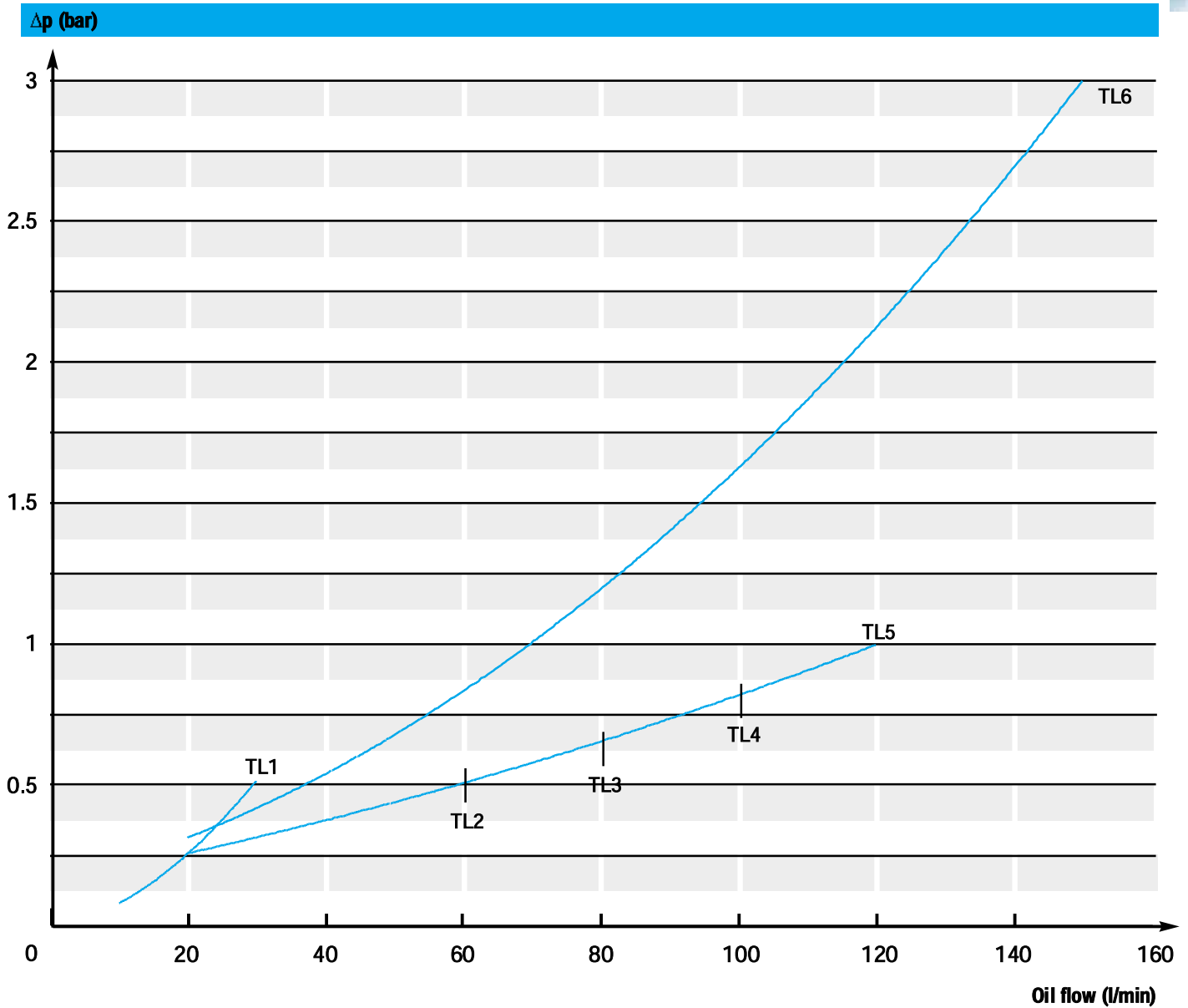

The pressure drop curves are based on a viscosity of $30 \text{ mm}^2/\text{s} = 30 \text{ cSt}$.

Please use conversion factor f from page 11, to calculate pressure drop at other viscosity's.

Selecting a cooling system

To select a cooler for your application, the following data is required:

- **Heat rejection:** Alternative terminology is dissipation
- **Oil flow:** Circulating oil flow determines the cooler size
- **Oil inlet temperature:** Temperature of the oil entering the cooler
- **Cooling air flow temperature:** Air temperature at cooler face before entering matrix

1. Determination of input data

P_{req} [kW]	Heat rejection
V_{oil} [l/min]	Oil flow
T_{oil} [°C]	Oil inlet temperature
T_{caf} [°C]	Cooling air flow temperature

Example

$P_{req} = 10$ kW
$V_{oil} = 50$ l/min
$T_{oil} = 70$ °C
$T_{caf} = 30$ °C

2. Specific heat rejection

ETD [K] = $T_{oil} - T_{caf}$ Entering Temperature Difference
 P_{shr} [kW/K] = P_{req} / ETD required specific heat rejection

ETD [K] = $T_{oil} - T_{caf} \Rightarrow 70\text{ °C} - 30\text{ °C} = 40\text{ °C} (= 40\text{ K})$
 $P_{shr} = P_{req} / ETD \Rightarrow 10\text{ kW} / 40\text{ K} = 0.25\text{ kW/K}$

3. Select according to diagram

P_{shr}/ETD [kW/K] actual specific heat rejection
 $P = (P_{shr} / ETD) \times ETD$ actual heat rejection

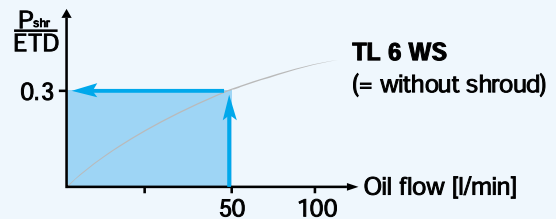

$P_{shr} / ETD = 0.3\text{ kW/K} \Rightarrow \text{TL6 WS}$
 $P = 0.3\text{ kW/K} \times 40\text{ K} = 12\text{ kW}$

4. Pressure drop / Oil temperature difference

Obtain pressure drop @ 30 cST oil viscosity from diagram on page 9. To calculate for other oil viscosities please use example on page 11.

$$\Delta T_{oil} \text{ [°C]} = 33 \times P[\text{kW}] / V_{oil} \text{ [l/min]}$$

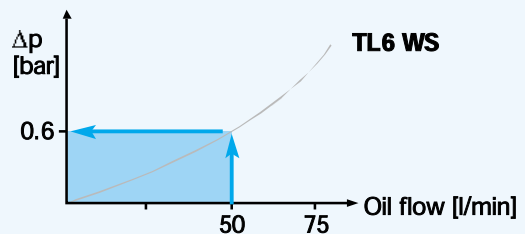

$$\Delta T_{oil} = 33 \times (12\text{ kW} / 50\text{ l/min}) = 7.9\text{ °C}$$

5. Results

selected cooler TL6 WS: heat rejection 12 kW, oil temperature difference 7.9 °C, pressure drop 0.6 bar

Conversion factors for different oil pressure drops

The pressure drop curves on pages 9 are based on a viscosity of 30 mm²/s = 30 cSt.
Please use conversion factor f to calculate pressure drop at other viscosities.

$\frac{\text{mm}^2}{\text{s}}$, cSt	10	15	20	30	40	50	60	80	100
f	0.5	0.65	0.75	1.0	1.2	1.4	1.6	2.1	2.8

Example:

Pressure drop of type TL4 is 0.75 bar @ 90 l/min and 30 mm²/s.
Assume an oil type ISO VG 46 is used @ 60 °C having a viscosity of 20 mm²/s.
To calculate new pressure drop multiply 0.75 bar by f = 0.75 to obtain the actual pressure drop 0.6 bar approximately.

Notes:

COUNTRY	LOCATION	COMPANY	TELEPHONE	FAX
AKG Sales Companies				
Germany	34369 Hofgeismar	AKG Thermotechnik International GmbH & Co. KG	+49 5671 - 8 83-0	+49 5671 - 35 82
Germany	77767 Appenweiler	Autokühler GmbH & Co. KG	+49 7805 - 4 98-0	+49 7805 - 4 98 10
China	Taicang	AKG Thermal Systems (Taicang) Co., Ltd.	+86 512 - 53 56 94 18	+86 512 - 53 56 94 11
France	Sarreguemines	AKG France S.A.S.	+33 3 - 87 95 11 11	+33 3 - 87 95 50 05
Latvia	Jelgava	SIA AKG Thermotechnik Lettland	+371 30 - 1 22 00	+371 30 - 1 22 09
Turkey	Izmir	AKG-SRF A.S.	+90 232 - 2 65 51 69	+90 232 - 2 65 51 70
United Kingdom	Tonyrefail	AKG UK Limited	+44 1443 - 67 80 50	+44 1443 - 67 06 06
United States of America	Mebane/NC	AKG Thermal Systems, Inc.	+1 919 - 5 63 48 71	+1 919 - 5 63 49 17
AKG Authorized Dealers (Europe)				
Austria	Graz	MfK-Tech	+43 3143 - 2 05 14 12	+43 3143 - 2 05 14 30
Czech Republic	Brno	BMC Baltas	+420 5 - 45 21 79 11	+420 5 - 45 22 60 48
Finland	Helsinki	Nestepaine OY	+358 9 - 61 36 33	+358 9 - 61 36 36 66
France	Paris	Domange Hydrauliques	+33 1 - 46 88 46 32	+33 1 - 47 90 03 57
Germany	09627 Oberbobritzsch	AT Cooling	+49 37325 - 75 53	+49 37325 - 9 28 72
Germany	15566 Berlin	Vogel & Partner Industrie-Hydraulik	+49 30 - 6 49 35 81	+49 30 - 6 49 35 84
Germany	17033 Neubrandenburg	Lippold Hydraulik & Wälzlager	+49 395 - 3 63 02 20	+49 395 - 3 63 02 29
Germany	34399 Oberweser-Gottstreu	Hega Antriebstechnik	+49 5574 - 18 42	+49 5574 - 4 18
Germany	41065 Mönchengladbach	Michael Widler Filtration und Kühlung	+49 2161 - 96 02 87	+49 2161 - 96 02 89
Germany	44369 Dortmund	Brenscheidt Autokühler	+49 231 - 93 11 93-0	+49 231 - 93 11 93 11
Germany	71691 Freiberg a. N.	SLB Industriekühler	+49 7141 - 29 09 02	+49 7141 - 29 09 05
Germany	78239 Rielasingen-Worblingen	Salzmann Kühler	+49 7731 - 86 84 88	+49 7731 - 86 84 49
Germany	80687 München	Kühlerbau Schneider	+49 89 - 54 70 10 66	+49 89 - 57 72 32
Germany	99974 Mühlhausen	Kämmer Antriebstechnik	+49 3601 - 44 40 13	+49 3601 - 44 40 14
Greece	Athens	Fluid Power Engineering	+30 210 - 5 58 04 02	+30 210 - 5 58 04 03
Greece	Athens	Motion & Control Ltd.	+30 210 - 3 41 10 11	+30 210 - 3 41 10 10
Netherlands	Rotterdam	Narim	+31 166 - 60 44 22	+31 166 - 60 33 22
Poland	Warsaw	IOW Trade	+48 22 - 6 15 81 21	+48 22 - 6 15 85 02
Russia	Moscow	Valitex	+7 95 - 2 25 95 86	+7 95 - 2 25 95 86
Spain	Madrid	Imprefil	+34 91 - 8 03 11 19	+34 91 - 8 03 47 56
Spain	San Sebastian	NovaHydra	+34 94 - 3 64 59 27	+34 94 - 3 64 06 23
Switzerland	Zurich	Autokühler Regensdorf	+41 44 - 8 40 65 00	+41 44 - 8 40 60 80
Switzerland	Lausanne	Mettraux Radiatech	+41 21 - 6 34 55 66	+41 21 - 6 35 78 77
Ukraine	Kiev	Gespaso	+380 44 - 5 37 04 64	+380 44 - 5 37 04 64
United Kingdom	Worcester	BYPY Hydraulics	+44 1584 - 87 30 12	+44 1584 - 87 66 47
United Kingdom	Wakefield	Hedley Hydraulics	+44 1924 - 25 99 99	+44 1924 - 25 22 11
United Kingdom	Edinburgh	Macscott Bond	+44 131 - 4 48 29 50	+44 131 - 4 48 29 41
United Kingdom	London	South Eastern Hydraulics	+44 1737 - 76 80 11	+44 1737 - 77 34 69
AKG Authorized Dealers (World)				
Argentina	Buenos Aires	Eurohidraulica	+54 1 - 1 47 96 59 63	+54 1 - 1 47 96 59 46
Australia	Hallam, Victoria	Fluid Dynamics	+61 3 - 97 96 59 88	+61 3 - 97 96 57 77
Brazil	São Paulo	Apema	+55 11 - 43 38 14 00	+55 11 - 41 27 60 97
India	New Delhi	Varalka Engineers	+91 11 - 41 58 93 69	+91 11 - 25 53 07 97
Malaysia	Kuala Lumpur	Alra/Altomac	+60 3 - 91 33 35 88	+60 3 - 91 30 03 16
South Africa	Johannesburg	Entramarc	+27 11 - 7 04 67 08	+27 11 - 7 04 60 91
South Korea	Seoul	Global	+82 3 - 28 72 04 01	+82 3 - 28 72 04 03

AKG – A World Class Supplier

The AKG group is one of the biggest suppliers of aluminium heat exchangers for industrial use world-wide. Coolers and cooling systems for various applications are manufactured in Germany and at many international production sites.

Hydraulic Coolers – Made by AKG



DIN EN ISO 9001 : 2000



AKG Thermotechnik International GmbH & Co. KG

P. O. Box 1346

D-34363 Hofgeismar

Telephone: +49 5671 - 8 83-0

Fax: +49 5671 - 35 82

E-Mail: info@akg-group.com

Internet: <http://www.akg-group.com>